

Achieving Success as Sergeant at Arms

Club Leadership Training Program





Achieving Success as Sergeant at Arms



THE MISSION OF THE CLUB

The mission of a Toastmasters club is to provide a mutually supportive and positive learning environment in which every member has the opportunity to develop communication and leadership skills, which in turn foster self-confidence and personal growth.

© Toastmasters International®

P.O. Box 9052 • Mission Viejo, California 92690 USA

949-858-8255 • Fax 949-858-1207

www.toastmasters.org

members.toastmasters.org

Printed in USA

Item 1311A (Part VII)

Revised 2008

Training Club Leaders... A Vital Function

As a coordinator for club leadership training, you have one of the most important roles in Toastmasters. The quality of a club meeting determines whether people join and stay in our organization. For a Toastmasters club, success lies in the ability to provide an environment that fosters meaningful self-development for all members. This is where officer training comes into play. Club officers must know their roles and responsibilities. The trainer's job is to explain this and make sure all officers understand why their roles are so important for the overall success of the club. By the end of the training session, the members of your audience will be familiar with the standards for this office. Your effectiveness as a trainer can make the difference between success and failure for a Toastmasters club.

Preparation is the key to a good training session. Review the manual, then study the training program thoroughly. Inject your own personality and experiences to create a session that is educational, enjoyable and motivational. Tips to help you prepare are provided in Part I. Part II is the training script while Part III has handouts, including an evaluation form, to distribute. Part IV contains copy for your visual aids. **This entire training program, including handouts and PowerPoint slides, is available for downloading on the Toastmasters International Web site, www.toastmasters.org.** Be sure to check the availability, condition and instructions for all electronic equipment prior to your training session. What would you do if your computer didn't work? What if you didn't know how to operate their brand of data projector? Be prepared with backup visuals, such as a flipchart, in case of technical failures. And be sure to arrange for help with any technical questions well before the event.

Table of Contents

Part I	Preparing for the Training Session	4
	Three Steps in Planning a Successful Training Program	4
	The Training Environment	5
	How to Use the Program Script	5
	Checklist for Club Officer Training	6
	Evaluation and Follow-up	7
Part II	Training Script	8
Part III	Handouts and Evaluation Form	20
Part IV	Visual Aids Copy	26

PART I: Preparing for the Training Session

Three Steps in Planning a Successful Training Program

1. Prepare the training agenda.

The information in the following script should be the core of your training session and should take about an hour to present. However, you may want to devote additional time to some subject areas or add other subjects for discussion, depending on the needs of the clubs. You should discuss your agenda with the Lt. governor education and training to ensure your program is appropriate.

2. Obtain and prepare materials.

- ▶ Prepare visuals using the master copies found in Part IV or on the Toastmasters International Web site. If a flipchart will be used instead of computer-based visuals, prepare it in advance: Write the information on every other flipchart page, using a marking pen and making sure all letters are large enough to be clearly visible to participants. Tips for effectively using visual aids are also included.
- ▶ Confirm the availability of computer equipment. If you are planning to use computer-based visual aids at the training site, you should know that providing such equipment is a locally-based decision, and not all districts have them on hand. So you may need to bring your own laptop computer and data projector. Also, some training locations may offer Internet access, so you can present the PowerPoint slides directly from the Toastmasters Web site. A better idea is to download the materials onto your computer before the event. This will protect you from annoying interruptions if your Internet access disconnects.
- ▶ Duplicate the handouts and evaluation form in Part III, along with any additional handouts you will distribute.
- ▶ Assemble reference materials. These may be available from the district, or you can order them through the Toastmasters International online catalog. Be sure to allow adequate time for shipping. If you are conducting training for a specific club officer, be sure to have a copy of the manual for that office. You'll refer to it throughout the training session.

3. Select training assistants.

You may want to have someone assist you in conducting the session (distributing handouts, etc.). Select that person in advance and explain what type of help you will need.

The Training Environment

A satisfactory physical environment is essential for an effective training session. In advance, arrange for your meeting room to be properly set up. You will need a room large enough to comfortably seat the attending officers. Ideally, it should have space in the back for coffee breaks as well as enough room in front to accommodate any electronic equipment and a work table for materials and supplies. Make sure you have a data projector, computer and screen if you are using computer-based visuals, and don't forget to include a spare bulb and extension cord.

The chart below illustrates an ideal physical setting for a training session.

KEY

- A** lectern and gavel
- B** projector and laptop computer
- C** flipchart
- D** screen
- E** table for materials and supplies
- X** participants
- Y** training assistants

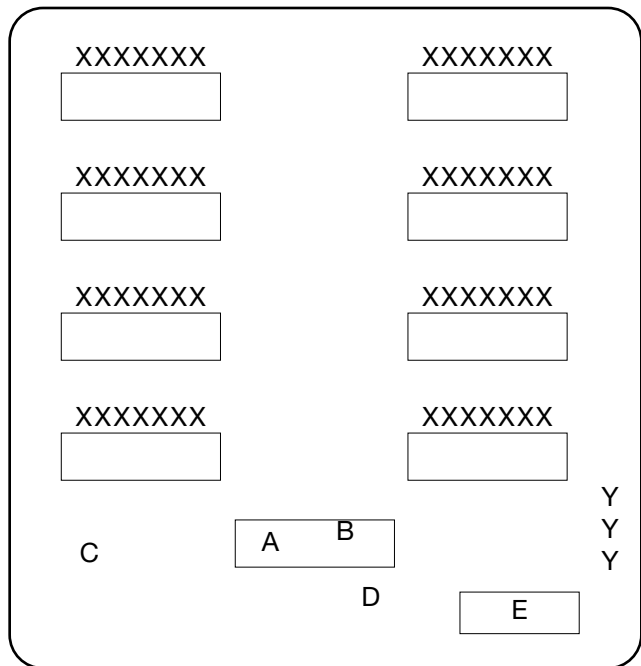

Upon arrival, check the room temperature. A room that is too hot or too cold is distracting and uncomfortable. Finally, greet and chat with as many participants as possible before beginning the session.

How to Use the Program Script

The training script in Part II is simple to use but requires considerable preparation. Its design allows presenters the opportunity to be flexible and creative and at the same time provides structure and ensures the important elements are emphasized. Because there is a lot of information, you may not be able to cover it all during the allotted time.

Interspersed throughout the script are boxed segments, offering explanations and guidelines for conducting group exercises and other portions of the training session. In the right column are keys to visual aids and space for your own notes.

When presenting the script, do not read it. Instead, become so familiar with the topic that you can paraphrase and embellish it to suit your own presentation style. Remember, new officers may not be familiar with Toastmasters jargon and acronyms such as CC and DTM.

Keep two things in mind when preparing for your training session:

- ▶ Fit your planned discussion to the time allotted.
- ▶ Allow ample time for group discussion and participation.

Manage your time from the start by asking your group which topics are most important to them, then cover those topics first. If time remains you can address the remaining topics. This means you may have to skip around in the script instead of following it in order.

Mention at the end of the session that they can find information on all of today's topics in their officer manual and point out other available resources on their "Resources List" handout.

Part III consists of handouts and an evaluation form to distribute during the session, as marked in the script. Be sure to make enough copies for everyone.

Part IV contains the basic visual aids for the program. Each is designated in the script in the right column as V #. PowerPoint visuals are available on the Toastmasters International Web site, or you can copy the text on a flipchart.

Checklist for Club Officer Training

- ___ Training assistants appointed
- ___ Projector, computer, screen, spare bulb and extension cord set up and tested
- ___ Web access confirmed, if needed
- ___ Flipchart and easel available, along with marking pens
- ___ Visual aids ready
- ___ Handouts reproduced and available
- ___ Room arranged and well-lighted
- ___ Coffee and refreshments ordered
- ___ Supplies and reference materials on hand
- ___ Notepads and pencils available for each participant

Evaluation and Follow-up

Ask the participants to fill out the evaluation form at the end of the session. Use this information in planning future training sessions.

Evaluate the trainees' use of materials. Be sure to follow up with club leaders throughout their term. Keep in mind that learning is a continuous process. Hold formal or informal review sessions as frequently as possible. If necessary, hold a make-up session for those who were unable to attend.

PART II: Presentation of the Training Session

PRESENTER: Welcome the group and present a brief opening address focusing on the importance of the club experience in the personal development of members. Your comments should be positive and motivational and should emphasize a commitment to member service in all aspects of the Toastmasters club. You also should mention the length of the training, the location of the rest rooms and phones, and other relevant information. But remember: Time is precious and must be controlled carefully throughout the session.

Opening Remarks

Serving as sergeant at arms is a great opportunity. You are responsible for arranging the meeting room, maintaining club properties, and establishing a warm environment for members and guests. You will learn and practice interpersonal communication skills, customer service, event planning and inventory management skills that you can use in all aspects of your life.

Today we're going to discuss your role as sergeant at arms and how to fulfill your responsibilities. Every club officer, including you, has performance standards to meet. These standards help officers clearly understand their roles and provide a point of reference for club members to better understand what to expect from club officers, to evaluate current leaders and candidates for office, and facilitate communication when expectations differ among club officers and members. The standards identify

performance members should expect from club officers outside of each club meeting and performance they should expect from club officers at the club meeting. In the next hour we're going to review your standards as sergeant at arms and discuss the steps you can follow to meet these standards. Later you'll be participating in some exercises to practice what you've learned.

HO #1**Your standards outside of the club meeting are to:**

1. Schedule the meeting location.
2. Maintain club equipment and supplies.
3. Arrange for a replacement if you are unable to attend a club meeting or for help if you need assistance.
4. Prepare your successor for office.

Your standards at the club meeting are to:

1. Arrange the room and equipment before the meeting begins.
2. Greet members and guests.
3. Greet visiting officers.
4. Arrange for food service.
5. Ensure the meeting starts on time.
6. Collect ballots and tally votes for awards.

Please keep in mind it's impossible to cover every detail of your responsibilities as sergeant at arms today. Our goal in this session is to provide you with a basic

foundation as well as with resources available from World Headquarters and the district. Feel free to ask questions. And remember to attend other sessions, all of which are intended to help you to succeed during your term of office.

The purpose of a Toastmasters club is to provide an environment in which members can learn communication and leadership skills. As the sergeant at arms of your club, you influence that environment. You serve as part of a team that consists of the president, vice president education, vice president membership, vice president public relations, secretary and treasurer. Each one of you is responsible for making your club dynamic and enjoyable for all members by working together as a team and for making sure the club is recognized at least as a Distinguished Club in the Distinguished Club Program. You can accomplish this by holding regular and productive executive committee meetings and through careful goal-setting, planning and monitoring of progress. The Distinguished Club Program recognizes clubs for achievement in education and membership growth and will be discussed in greater detail during a separate training session.

Now let's discuss some of the standards mentioned earlier. Because of our limited time, we may not be able to discuss them all. But I do want to address the ones you are most concerned about. Please look at the list of standards I gave you and tell me which ones you want to cover today.

PRESENTER: List suggestions on the flipchart. Be sure to discuss the most requested items first, then discuss the others as time permits. This means you may have to skip around in the script instead of following it in order.

Your standards outside of the club meeting are to:

- ▶ **Schedule the meeting location.** Without a meeting room, your club can't meet. You are responsible for working with those who manage the meeting site to secure the room for club meetings. Some clubs schedule their meetings a month or two in advance, while others schedule them six months or more in advance. Follow your club's custom. Be sure to confirm the room reservation before each meeting and let meeting site management know in advance if the club's plans change. Such courtesies help maintain a good relationship with the meeting site management.

- ▶ **Arrange for a replacement or for assistance.** Occasionally you may not be able to attend a club meeting or you know you will be late. In these cases, arrange for someone to handle your tasks for you. Otherwise, someone else will be rushing at the last minute to prepare the meeting room in your absence. As a result, the meeting may start late and not proceed smoothly. Likewise, if you know you will be tardy, ask someone to do your tasks until you arrive. And if the club has a special event which requires extra attention, arrange for someone to assist you.

- ▶ **Prepare your successor for office.** As you gain experience during your term, take notes and think of how you will prepare the person who will come after you. Give all necessary records and materials to your successor and offer to assist the new officer as he or she is learning the sergeant at arms duties.

- ▶ **Maintain club equipment and supplies.** After each meeting, pack up all club property and store it in a secure place. Some clubs have storage space at the meeting place in a closet or on a shelf. In other cases, the sergeant at arms keeps it between meetings. Make sure the timing light is in good repair. If the supplies of name badges, ballots, or other items are low, ask the club secretary to order more.

Additional Note on Equipment:

Some clubs pool their individual members' financial resources and purchase equipment for general use at club meetings and conferences. The sergeant at arms may wish to coordinate efforts on the club's behalf to attain these items and determine a secure location for their storage.

CAUTION: Toastmasters policy limits what a club is allowed to own as an asset.

Acceptable assets include:

- ▶ Coffee makers
- ▶ Lecterns
- ▶ Banners
- ▶ Stationery
- ▶ Mailing supplies
- ▶ Timing lights
- ▶ Recognition awards (such as trophies)
- ▶ Audiovisual equipment (such as a data projector and screen)
- ▶ Sound systems
- ▶ Similar equipment (such as flipcharts and easels)
- ▶ Educational materials

It is **NOT** acceptable for a club to own or rent assets such as the following:

- ▶ Motor vehicles
- ▶ Office space
- ▶ Real property
- ▶ Furniture
- ▶ Telephones and telephone systems
- ▶ Other items not listed here; check with World Headquarters if in doubt

According to Toastmasters International policy, each club must maintain a written list of its assets *and* a written process to ensure that the assets are accounted for and transferred smoothly to future club officers. The sergeant at arms may keep this list current as part of maintaining the club's equipment and supplies. If keeping a written list poses difficulties, ask the club secretary to help.

SA-V #2**Your standards at the club meeting are to:**

- ▶ **Arrange the room and equipment before the meeting begins.** Just as actors rely on a production staff to supply scenery, lighting and sound effects, Toastmasters clubs rely on their sergeant at arms to set the stage properly. Arrive 30 minutes early to provide ample time to arrange the tables and chairs. Once the seating is arranged, set out your club's lectern, gavel, banner, timing lights, ballots and any other item or material required. Be sure to place a table near the door to display your club's guest book (Item 84), promotional brochures (Items 99, 100), name tags (Item 231) and other visitor-oriented materials. For example, if some of your members belong to more than one club, encourage them to donate their extra copies of the *Toastmaster* magazine. Guests appreciate being able to take something home to review. Also be sure to display a copy of the Catalog (Item 1205) so that members and guests are aware and can take advantage of all that Toastmasters has to offer.
- ▶ **Greet guests and members.** Remember the first time you visited your Toastmasters club? You weren't sure what to expect, but from the moment you entered the room, someone was there to greet you, introduce you to others, and perhaps explain a little about the Toastmasters organization before the meeting began.

Now, as sergeant at arms, it's up to you to present that vital first impression. Anxious visitors should relax once they shake your hand and hear your welcome. Current

members appreciate your reliability and depend on you to create a friendly and comfortable atmosphere that will allow them to stretch and develop their abilities.

All members should be encouraged to welcome visitors and fellow members to each meeting. As sergeant at arms, however, it is your official duty to extend this courtesy and set an example for other club members. Smile and welcome everyone as they enter and pay special attention to guests and new members. Ask guests to sign the guest book and make sure each receives a name tag to wear during the meeting. Then introduce each guest to at least one other member, and arrange for both guests and new members to sit with experienced members who will answer any questions that may arise during the meeting. During the meeting, sit near the door so you can welcome late arrivals, prevent interruptions and do any necessary errands. Try to anticipate situations before they occur. Always be ready with extra chairs, meeting agendas and any other materials necessary to the meeting.

- ▶ **Greet the area governor and other visiting officers.** Occasionally the area governor or other district officer may visit your club. Welcome the officer, introduce yourself and escort him or her to the club president.

PRESENTER: Take some time to conduct a brainstorming session with the audience. What are some ways the sergeant at arms can open a conversation with a guest? Discuss some of the questions the sergeant at arms might ask, such as whether the guest has attended a meeting before, and how that person first heard about Toastmasters. If time permits, invite some role playing. Have one person play the part of the sergeant at arms and ask others to portray people who might visit a Toastmasters club: the shy, nervous introvert; the business person eager for advancement; the corporate worker who feels somewhat

antagonistic since his manager has required him to join a club; the Toastmaster returning after a lapse in membership; the Toastmaster who has just relocated to your area and wishes to transfer her membership.

- ▶ **Arrange for food service.** Some clubs hold their meetings at restaurants and plan a meal as part of the pre- or post-meeting agenda. Other clubs schedule events apart from their regular meetings that take place at a banquet hall or restaurant. If your club includes breakfast, lunch or dinner as part of its proceedings, it is your responsibility to determine how many and what kinds of meals must be prepared and to notify the restaurant. Often this involves the collection of payment from members. Plan to collect all money before the meeting begins or during a break. Arrange to have coffee and tea available at each table so members will be less likely to move around while someone is speaking.
- ▶ **Ensure the meeting starts on time.** The Toastmasters educational program teaches meeting leadership and management. One important point we stress is that meetings start and end on time. Members, guests and club officers often socialize before the meeting begins and do not pay attention to time. Your role is to pay attention to time and warn the club president several minutes before the meeting is scheduled to begin. Your efforts will help the meeting to begin on time.
- ▶ **Collect ballots and tally votes for awards.** If your club presents awards to the “Best Speaker,” “Best Evaluator” and others during most club meetings, you also will be responsible for the voting process. Keep a supply of blank ballots (Item 163) on hand and distribute them before the meeting begins. When members have marked their ballots, collect them and count the votes for each award. Give the results to the Toastmaster, or announce them yourself when called upon for the results.

PRESENTER: Show the manual and open it to the checklist page. Point it out to the group.

The manual, *When You Are the Sergeant at Arms*, offers a “Meeting Room Checklist” to help you keep track of your duties. While learning your role, you may wish to make a few personal copies of this list and check off each item as it is completed for the day. This will help you to learn your role and ensure that all duties are carried out.

Sometimes trying to do all of these things during a short time can be difficult. Instead of facing burnout, you may organize a committee to help you share the various tasks. Other members then have a chance to contribute and you, as committee chairman, have the opportunity to practice leadership skills.

PRESENTER: Take some time to conduct a brainstorming session with the members of your audience. Ask what special challenges their meeting areas present with regard to seating and arrangement of materials. Other than the items just mentioned, do they have other materials or equipment that must be considered in the set-up procedure? Have each person think of three items that add to the club’s atmosphere or promote the educational purposes of Toastmasters, then share them with the rest of the group.

PRESENTER: This handout is a list of resources.

PRESENTER: Continue with the following case studies. The participants' handouts for this are located in Part III for copy and distribution. Afterward, if you have time, answer questions and perhaps give a short motivational closing.

Case Study for Sergeant at Arms**Dealing with Food Issues****HO #3**

Objective: To deal with obstacles that might prevent you from performing your job well

Time: 15 minutes

- Process:**
1. Distribute copies of the case studies sheet in Part III to the training session participants.
 2. Select one of the case studies for the group exercise. You may suggest that they work through the other case study with their fellow club officers at another time.
 3. Break the participants into groups of three.
 4. Have each group brainstorm two solutions. Record one idea from each group on a flipchart.

Recommended Solutions:

- ▶ Talk with the location management and try to work something out. If this proves to be futile, bring up your problem at your executive committee meeting. The committee may decide to change the meeting place once they have conferred with club members.
- ▶ They executive committee can ask the club members if anyone works at a location that has a break room available. Alternately, you can research local restaurants and suggest meeting in one, though you would then also have to ask the members if they would be willing to purchase lunch from the restaurant.

Case Study for Sergeant at Arms**Preparing for the Meeting****HO #4**

Objective: To deal with obstacles that might prevent you from doing your job

Time: 15 minutes

- Process:**
1. Distribute copies of the case study sheet in Part III to the training session participants.
 2. Break the participants into groups of three.
 3. Have each group brainstorm two solutions. Record one idea from each group on a flipchart.

Recommended Solutions:

- ▶ Talk with the restaurant management and try to work something out. If this proves to be futile, bring up your problem at your executive committee meeting. The committee may decide to change the time or meeting place once they have conferred with club members.

PART III: Handouts

The following handouts may be reproduced for distribution to your training session participants. Make certain you accurately project the number of attendees so you have enough.

Feel free to revise the material to suit your own style.

HO #1

SERGEANT AT ARMS STANDARDS

Outside of the club meeting

1. Schedule the meeting location
2. Maintain club equipment and supplies
3. Attend club executive committee meetings
4. Attend district-sponsored club officer training
5. Arrange for a replacement if you are unable to attend a club meeting or for help if you need assistance
6. Prepare your successor for office

At the club meeting

1. Arrange the room before the meeting begins
2. Greet members and guests
3. Greet visiting officers
4. Arrange for food service
5. Ensure the meeting starts on time
6. Collect ballots and tally votes for awards

HO #2

RESOURCES LIST

Achieving Success as Sergeant at Arms

Following are some materials you may want to order to ensure a successful term as sergeant at arms:

QUANTITY		TOTAL
_____	1310O Sergeant at Arms Essentials \$16.00	\$ _____
_____	1310G When You Are the Sergeant at Arms manual \$2.50	\$ _____
_____	1111 Distinguished Club Program / Club Success Plan \$1.25	\$ _____
_____	163 Ballots and Brief Evaluations... Perforated form with ballots for best speaker, evaluator, and Table Topics Speaker, with space for brief comments (Quantity 500) \$12.95	\$ _____
_____	1205 Supply Catalog \$1.00 (up to 4 free)	\$ _____
_____	1205A Catalog Order Blanks	\$ <u> N/C </u>
_____	84 Guest Book \$8.00	\$ _____
_____	231 Guest Badge – Visitor’s Card (set of 25) \$3.50	\$ _____
TOTAL		\$ _____
CA clubs add 7.75%		\$ _____
TOTAL AMOUNT		\$ _____

Mail to: Toastmasters International
 P.O. Box 9052, Mission Viejo, CA 92690 USA
 or telephone 949-858-8255, Fax No. 949-858-1207

U.S. SHIPPING CHARGES

WEIGHT	STANDARD	1 DAY COURIER	2 DAY COURIER
.00 - .81	\$3.50	\$20.50	\$10.25
.82 - 2.00	\$5.00	\$26.80	\$11.65
2.01 - 3.00	\$5.75	\$29.15	\$12.85
3.01 - 4.00	\$6.10	\$31.55	\$14.20
4.01 - 5.00	\$6.50	\$33.85	\$15.60
5.01 - 6.00	\$6.60	\$36.15	\$17.05
6.01 - 7.00	\$6.75	\$38.35	\$18.55
7.01 - 8.00	\$7.00	\$40.55	\$20.10
8.01 - 9.00	\$7.25	\$42.70	\$21.75
9.01 - 10.00	\$7.50	\$44.85	\$23.30
10.01 and up	\$7.75 + .75 Each additional lb. (or portion thereof)	\$47.00 + \$2.00 each additional lb. (or portion thereof)	\$24.75 + \$1.50 each additional lb. (or portion thereof)

See current catalog for International rates.

PAYMENT MUST ACCOMPANY ORDER

___ Enclosed is my check in the amount of \$ _____ (U.S.) OR
 ___ Please bill against my MasterCard / VISA / AMEX / Discover (Circle one)

Credit Card No. _____ Expiration Date _____

Signature _____

Name _____

Club No. _____ Club Name _____

Address _____

City _____ State/Province _____

Country _____ Postal Code _____

E-mail _____ Phone No. _____

HO #3

CASE STUDY #1

CASE STUDY FOR SERGEANTS AT ARMS:

FOOD ISSUES

Your meeting location is convenient for your club members who work in nearby businesses.

However, the site does not allow food, and the meetings take place over lunch break for the club's many working members. Several members have been bringing sack lunches to the meeting, and since they must return to work immediately after, this is their only opportunity to eat mid-day. The owner of the property has been very clear about the "no food" rule. What do you do?

HO #4

CASE STUDY #2

CASE STUDY FOR SERGEANTS AT ARMS: PREPARING FOR THE MEETING

Your club meets at 7 a.m. every Thursday, and as sergeant at arms, you have decided to arrive at 6:30 a.m. to set out club materials and equipment. However, you have difficulty getting into the restaurant where your meetings are held because the restaurant staff has been late consistently for the last couple of weeks. As a result, your meetings are starting late because you are still setting up the room at 7 a.m.

HO #5

Evaluation Form

Date: _____ Program Name: _____

Facilitator: _____

On a scale of one to five, five being the highest rating, please rate the course and facilitator on the following items by circling the number you find most appropriate:

- | | | | | | |
|--|---|---|---|---|---|
| 1. How relevant was this session to your job in Toastmasters? | 1 | 2 | 3 | 4 | 5 |
| 2. Rate the following: | | | | | |
| Course content | 1 | 2 | 3 | 4 | 5 |
| Course material | 1 | 2 | 3 | 4 | 5 |
| Facilitator | 1 | 2 | 3 | 4 | 5 |
| Activities/exercises | 1 | 2 | 3 | 4 | 5 |
| 3. Were the objectives clearly stated? | 1 | 2 | 3 | 4 | 5 |
| 4. How was the lesson plan organized? | 1 | 2 | 3 | 4 | 5 |
| 5. Did the instructional methods clearly illustrate the instructor's plan? | 1 | 2 | 3 | 4 | 5 |
| 6. To what extent did the visual aids add to your understanding of the presentation? | 1 | 2 | 3 | 4 | 5 |
| 7. How were the meeting facilities? | 1 | 2 | 3 | 4 | 5 |
| 8. What are two things you learned that will make you a more effective club officer? | | | | | |

Additional Comments:

PART IV: Visual Aids Copy

Materials on the following pages are designed specifically for the presenter to use in conducting the training session. To use them as a PowerPoint show, you will need a laptop computer, data projector and screen, and slides that you can download from the TI Web site. Alternatively, you can reproduce the slides as transparencies for use on an overhead projector, or handwrite them on a flipchart.

In the right-hand column of the script are keys for visual aids. Their placement indicates the points at which they should be displayed. Each is numbered. For example, SA-V #1 stands for “the first visual.”

Tips

1. Show the visual aid only while you are talking about it. If you're using PowerPoint, click on the next slide when you are ready to discuss it.
2. Be sure everyone in the audience can see the visuals clearly. Visibility to the people at the rear of the room is your guide.
3. Talk to the audience, not to the visual. Maintain eye contact even when your listeners are looking at the visual. This will help you judge their understanding.
4. Don't overdo it. You need not illustrate every point in the speech.
5. Rehearse. Nothing is more important than adequate preparation. Know how and when you will use the visual, and practice so you will make a smooth presentation. Anticipate all possible problems, especially when electronic equipment is involved.
6. Remember...be as professional as possible.